

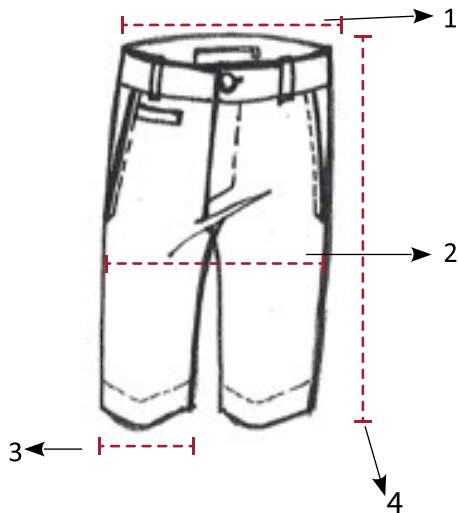

**CAPOBIANCO**  
MADE IN ITALY

If you have not already purchased items of our brand we recommend you to rely to the conversion table below in order to choose your correct size. For any doubt please email us to the following address: [info@capobianco.org](mailto:info@capobianco.org)

		46 (IT) - 42 (EU)	48 (IT) - 44 (EU)	50 (IT) - 46 (EU)	52 (IT) - 48 (EU)	54 (IT) - 50 (EU)	56 (IT) - 52 (EU)	58 (IT) - 54 (EU)	60 (IT) - 56 (EU)	62 (IT) - 58 (EU)	Tolerance CM+/CM-
1	Half waist width	40	42	44	46	48	50	52	54	56	0,5
2	Half pelvis (from the fly) width	50	52	54	56	58	60	62	64	66	1
3	Half leg opening width	22.2	23	23.8	24.6	25.4	26.2	27	27.8	28.6	1
4	Total side length + belt	49.5	51.5	52.5	53.5	54.5	55	55.5	56	56.5	1



#### How to Measure:-

- 1. Waist Width:** Lay the pants flat (front side up) on a horizontal surface. Measure the distance at the narrowest point of the waistband from one end to the other.
- 2. Hip Width, below the pocket:** Lay the pants flat (front side up) on a horizontal surface. Measure the distance, keeping the tape measure below the pockets, from one side to the other.
- 3. Leg Opening Width:** Lay the pants flat (front side up) on a horizontal surface. Measure the distance at the narrowest point of the leg opening from one end to the other.
- 4. Leg Length, inseam:** Lay the pants flat (front side up) on a horizontal surface. Measure the distance from the crotch down to the bottom end of the pants.